

# Invizible™ Water Heater

**IDEAL APPLICATIONS:** Public Lavatory

## Invizible™ PRODUCT FEATURES

- Invizible™ wall sleeve conceals your Chronomite Heater inside the wall
- Chassis is ideally suited for new installations or for remodeling in masonry, tile, wood or other wall surfaces
- Series starts with 3-1/4" Depth Chassis allowing for standard wall depth installations
- 6 entry points to route electrical and water connections in any direction as needed per installation
- 4 bottom entry points constructed with knockouts for bulkhead and or sealed installation
- Slots in Chassis allow for different wall thicknesses and allow easy adjustment to align Wall Frame
- 1/4" mounting holes (Quantity 12 in chassis)
- Door/Frame (16 gage) and Chassis (20 gage) are fabricated from galvanized steel with a prime coat white finish
- Concealed Pivoting Rod Hinge prevents distortion and closes door squarely
- Pem Studs #8-32 are provided on chassis for easy mounting of CMI series heater
- Models with Electrical Disconnect are pre-wired for ease of installation
- Latch is screwdriver operated (Standard Models)
- Door Frame is one piece construction, 1" wide and provides perfect concealment of the rough wall opening
- Door has rounded safety corners
- Patent Pending



Z-C1616 Shown

## GUIDE SPECIFICATION

Wall Sleeve shall be a Chronomite Laboratories Model

Z - \_\_\_\_\_

\_\_\_\_\_ OPTIONS

Unit shall be fabricated from galvanized steel with a white prime coat finish suitable for painting. Access door shall have rounded safety corners and concealed pivoting rod hinge. Door/Frame 16 gage and wall sleeve 20 gage thickness. Latch shall be screwdriver operated. Wall Sleeve to have 10 entry points including 4 knockouts for bulkhead and or sealed installation.

### OPTIONS

- -AKL Allen Key Latch
- -CL Cylinder Lock (one per door)
- -SS Stainless Steel Construction (Type 304 No. 4 Satin Finish)

MODEL NUMBERS	NOMINAL SIZE	WALL OPENING	ELECTRICAL DISCONNECT
Z-C1616	16" x 16"	16-1/2" X 16-1/2" x 3-1/4"	NO
Z-C1616D	16" x 16"	16-1/2" X 16-1/2" x 5-1/4"	YES / PRE-WIRED

Complies with Standards for:

### CHRONOMITE LABORATORIES, INC.

17451 Hurley St. :: City of Industry, CA 91744  
Phone 800-447-4962 :: 626-937-4270  
Fax 626-937-4279 :: www.chronomite.com

MEMBER OF



# Invizible™ Water Heater

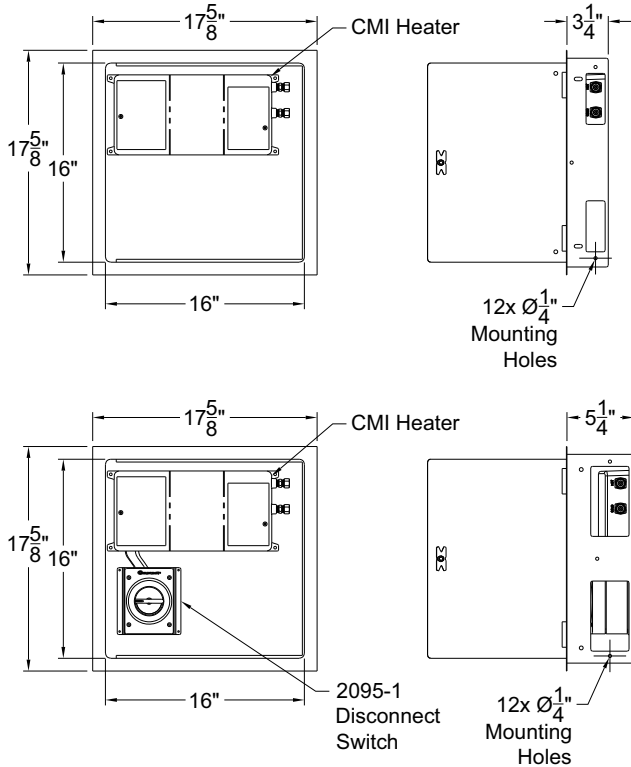

## CMI Series Heater

### GUIDE SPECIFICATION

Tankless Water Heater shall be a Chronomite Laboratories Model

CMI -        L /        VOLTS

AMPS

       OPTIONS

with        Amps and        Volts

to heat to a preset temperature of

- 104°F (40°C)
  - 110°F (43°C)
- ( Meets ADA )

Unit shall be provided with Celcon waterways, and Nichrome heating coils. Temperature controlled by microprocessor and integrated thermostatic mixing valve meeting ASSE 1069, CSA B125.3-12 and ASSE 1070 compliancy.

#### OPTIONS

- 1/2" Male NPT (NPT08)
- Disconnect Switch, Rotary 40A - Lockable Nema 4X (2095-1)

**For the model being selected, please place the corresponding amps and volts values in the Guide Specifications to the right.**

MODEL	AMPS	VOLTS	90°C WIRE	WATTS	ACTIVATION GPM	°F TEMPERATURE RISE @				
						0.35 GPM	0.50 GPM	1.00 GPM	1.50 GPM	2.00 GPM
CMI-12L/120	12	120	14 AWG	1440	0.20	28	20	---	---	---
CMI-12L/208	12	208	14 AWG	2500	0.20	49	34	---	---	---
CMI-12L/240	12	240	14 AWG	2880	0.20	56	39	20	---	---
CMI-12L/277	12	277	14 AWG	3320	0.20	65	45	23	---	---
CMI-15L/120	15	120	14 AWG	1800	0.20	35	25	---	---	---
CMI-15L/208	15	208	14 AWG	3120	0.20	61	43	21	---	---
CMI-15L/240	15	240	14 AWG	3600	0.20	70	49	25	---	---
CMI-15L/277	15	277	14 AWG	4150	0.20	81	57	28	---	---
CMI-20L/120	20	120	12 AWG	2400	0.20	47	33	---	---	---
CMI-20L/208	20	208	12 AWG	4160	0.20	81	57	28	---	---
CMI-20L/240	20	240	12 AWG	4800	0.20	90+	66	33	22	---
CMI-20L/277	20	277	12 AWG	5540	0.20	90+	76	38	25	---
CMI-30L/120	30	120	10 AWG	3600	0.20	70	49	25	16	---
CMI-30L/208	30	208	10 AWG	6240	0.20	90+	85	43	28	21
CMI-30L/240	30	240	10 AWG	7200	0.20	90+	90+	49	33	25
CMI-30L/277	30	277	10 AWG	8310	0.20	90+	90+	57	38	28
CMI-40L/208	40	208	8 AWG	8320	0.20	90+	90+	57	38	28
CMI-40L/240	40	240	8 AWG	9600	0.20	90+	90+	66	44	33

Note 1: Maximum temperature rise may be governed by preset outlet temperature.

Note 2: Local plumbing and electrical codes must be followed for installation of water heater and the accessories.

Chronomite Laboratories assumes no responsibility for use of void or suspended data. © Copyright Chronomite Laboratories, Inc. Member of Morris Group International, City of Industry, CA Please visit [www.chronomite.com](http://www.chronomite.com) for most current specifications.

<b>SELECTION SUMMARY &amp; APPROVAL FOR MANUFACTURING</b>	Company _____	
	Model Number & Options _____	Quantity _____
	Contact _____	Title _____
	Signature (Approval for Manufacturing) _____	
	Date _____	

**CHRONOMITE**  
LABORATORIES, INC.  
PH. 800-447-4962  
626-937-4270  
FAX 626-937-4279  
[www.chronomite.com](http://www.chronomite.com)